

Baxter Headboard

ASSEMBLY INSTRUCTION

DARCYANDDUKE.COM.AU
f @DARCYANDDUKE

DARCY
& DUKE

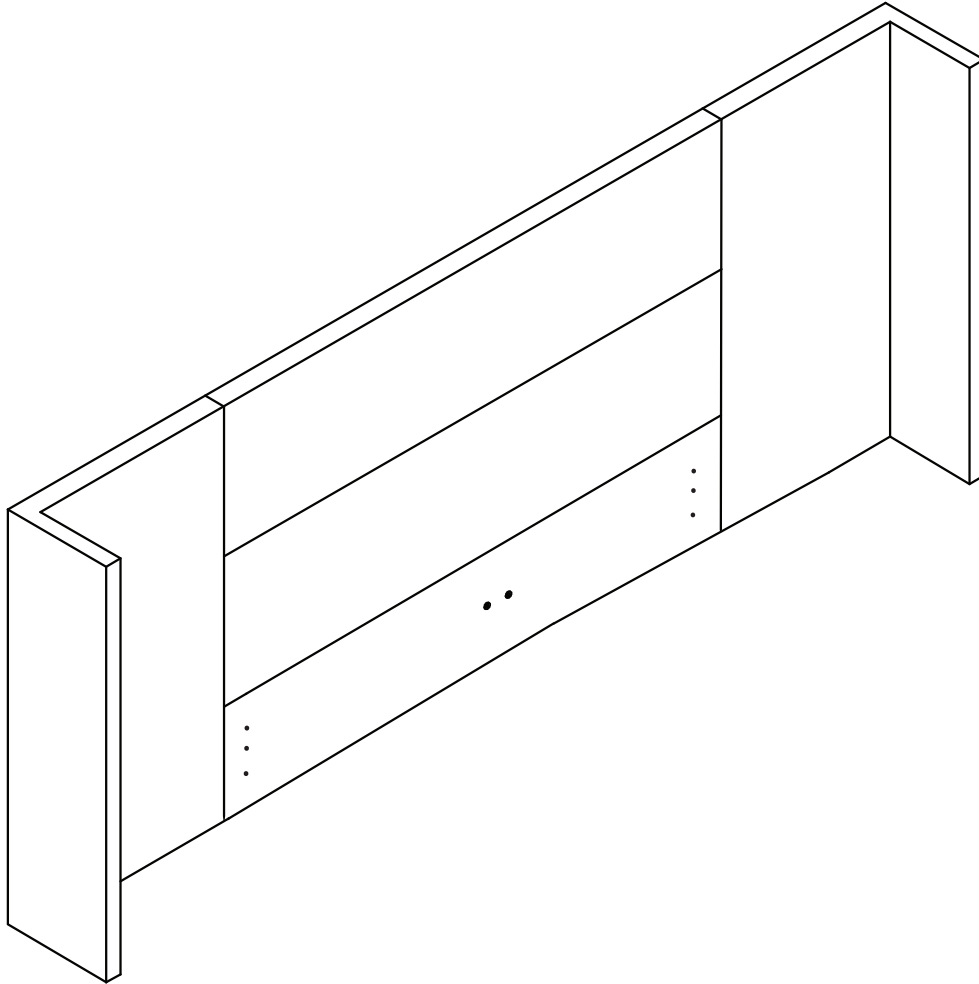

15 MINS

APPROXIMATE ASSEMBLY TIME



2 PERON ASSEMBLY

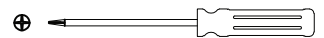

REQUIRED ASSEMBLY TOOLS

PLEASE NOTE: DO NOT FULLY TIGHTEN ALL SCREWS UNTIL THE ITEM IS ASSEMBLED.

ALL PARTS

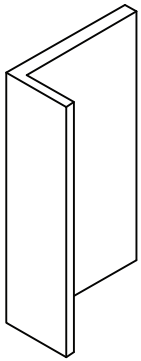

(8) WING X 2 (R & L)



C. WASHER X 16 (M8)



F. BOLTS X 8 X M6 X 40MM

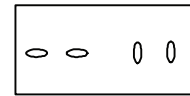

H. WOOD CONNECTING BAR X 4



G. TAPPING SCREW X 12

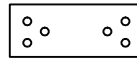

I. METAL CONNECTING PLATE X 2

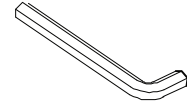

J. ALLEN KEY X 1 M6

ASSEMBLY

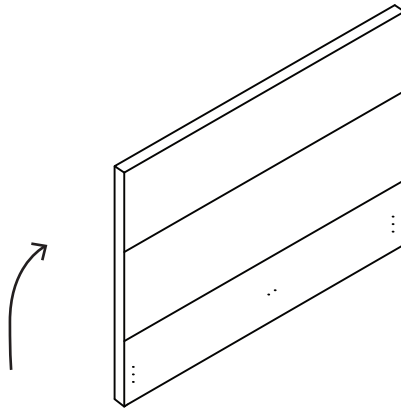

STAND THE HEADBOARD UPRIGHT

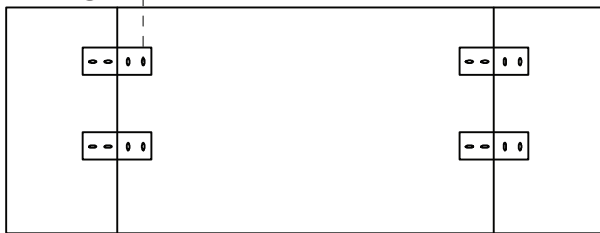
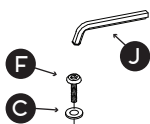

BACK SIDE VIEW OF HEADBOARD

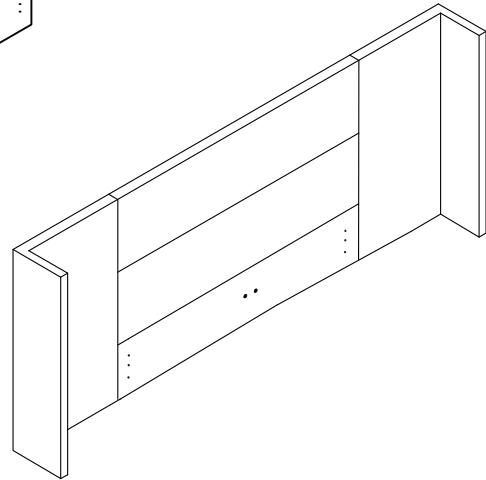

BOTTOM VIEW OF HEADBOARD

CONNECT BOTH WINGS TO THE HEADBOARD.
USE METAL PLATES UNDERNEATH TO STRENGTHEN THE CONNECTION.